

TekSpan® Zynox 45 Opti-Lock Bolt M10x15

Product Code: 60126

Description

8.8g Opti-Lock Bolt with locking washer - locks securely through frame slots with locating collar and captive serrated washer "bites" into bracket fixture, providing exceptional joint strength.

Technical Details

Pack Qty	50
Weight	0.0550kg/pc
Material	Steel
Finish	Zinc-Nickel
Strength Class	8.8
Max load Fx	3kN
Max load Fy	8kN
Max load Fz	4.5kN
Thread	M10
Length thread	15mm
Tightening torque	50Nm
Overall length	32mm
Width hammer head	10mm
Diameter washer	30mm
Length hammer head	20mm
Thickness hammer head	10mm
Thickness washer	5mm
Profile size	45mm

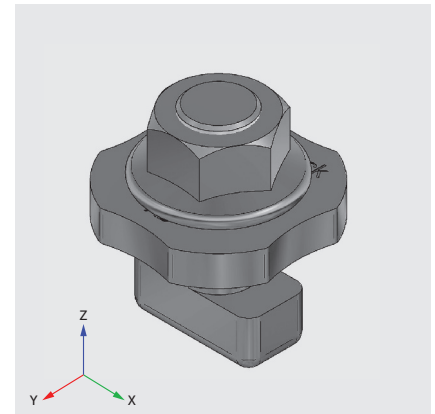

Data Centre Compatibility

No whisker formation occurs with the zinc-nickel bolt. In contrast to pure zinc coatings, there is no whisker formation when zinc-nickel is deposited as an alloy and intermetallic phase.

This has been tested using parts with the acidic zinc-nickel electrolyte used. The zinc-nickel parts were provoked with several influencing factors and no whiskers could be detected at any time.

Zinc-nickel coated parts are therefore highly suitable for use in data centres.

Certifications



The complete system meets the requirements of standard EN 1090